

INSTALLATION MANUAL

LED SHOEBOX / PARKING LOT LIGHT

 **WARNING**

1. To avoid electric shock, disconnect power at the source prior to installation.
2. The installation needs to be conducted by a certified electrician to ensure proper installation.
3. If there are problems with the fixture, turn off power and do not attempt to repair unless you are a certified electrician.
4. The electrical rating of this product is 120-277VAC or 347VAC (refer to product label to determine).
5. 120-277VAC version may come with a photocell. Please refer to product package before installation.
6. Read label information carefully to ensure proper input voltage for this product.

Installation-Split Fitter

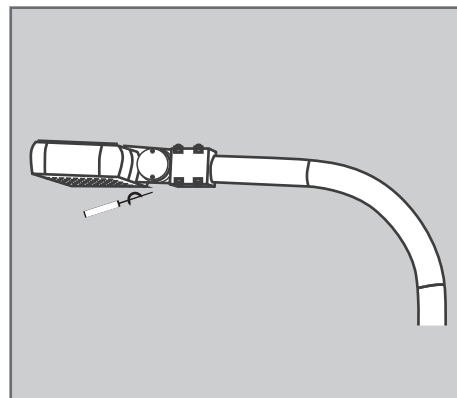
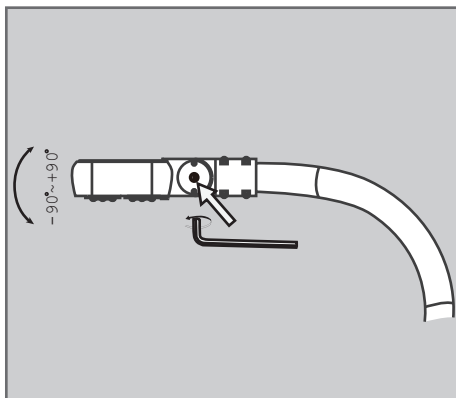
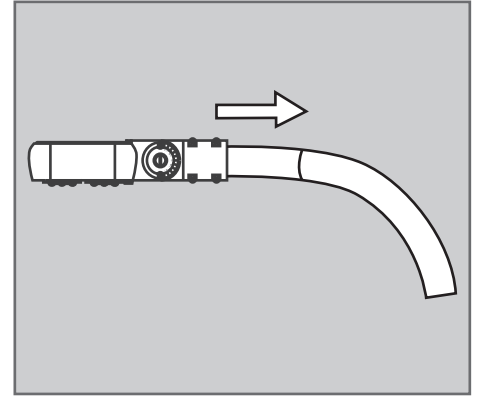
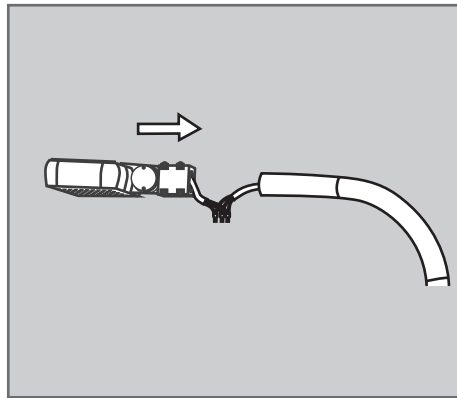
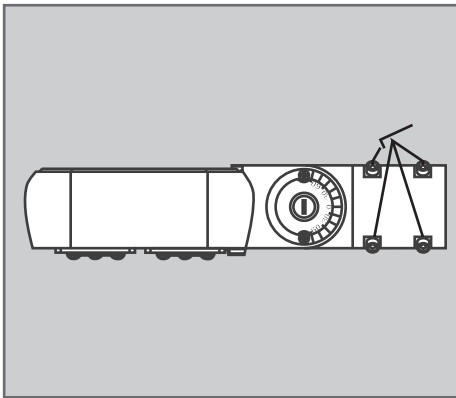

INSTALLATION MANUAL

LED SHOEBOX / PARKING LOT LIGHT

Installation-Direct Mounting

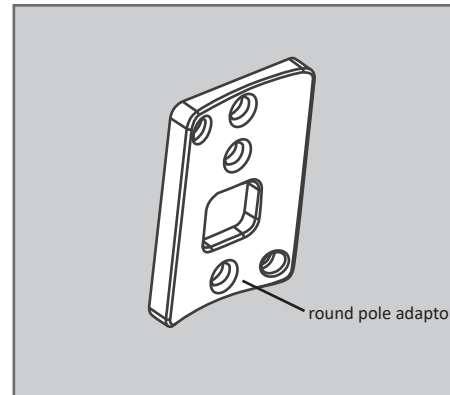
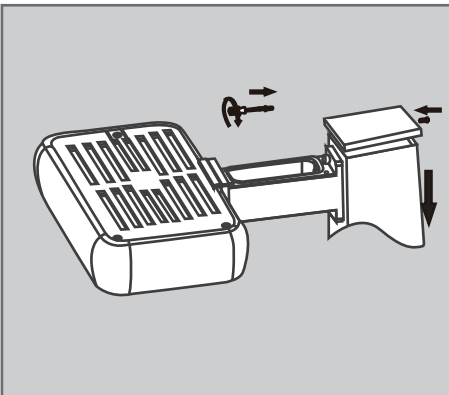
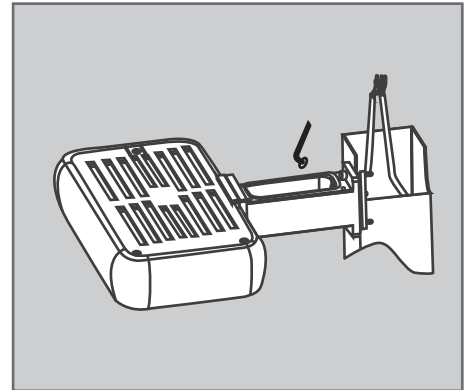
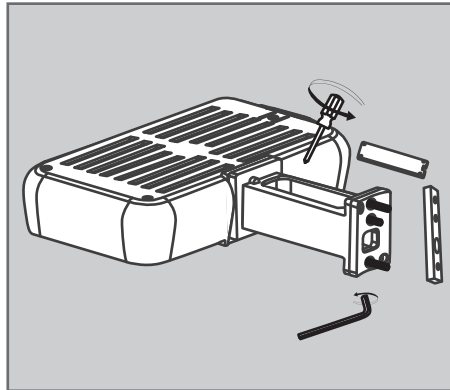
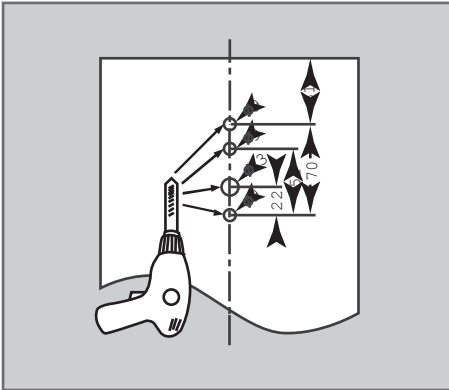

INSTALLATION MANUAL

LED SHOEBOX / PARKING LOT LIGHT

Installation-Trunnion Mounting

